

G5RV Multi-band Antenna

by Louis Varney, G5RV

On 28 June 2000, at 89, Louis Varney, alias G5RV, rejoined the large family of silent keys hams. To pay tribute to this famous radio amateur, I would like to present you one of the main work he shared with the ham community : the invention of the G5RV dipole antenna.



“He never made a penny out of his invention, that has been copied by many, improved by some , studied by many others using computers, and manufactured and sold by many companies worldwide.”



Louis Varney, SK

Louis Varney (G5RV) –SK, served in the Royal Corps of Signals in an HF Interception and DF unit , and was rapidly promoted to Captain. He was demobbed in 1946 and moved to a house in Stony Stratford that had a garden barely 100ft long -and a need for a multi-band HF antenna. Eventually Louis came up with the design now universally known as

“The G5RV Multi-band HF Dipole”

Louis Varney's Classic G5RV

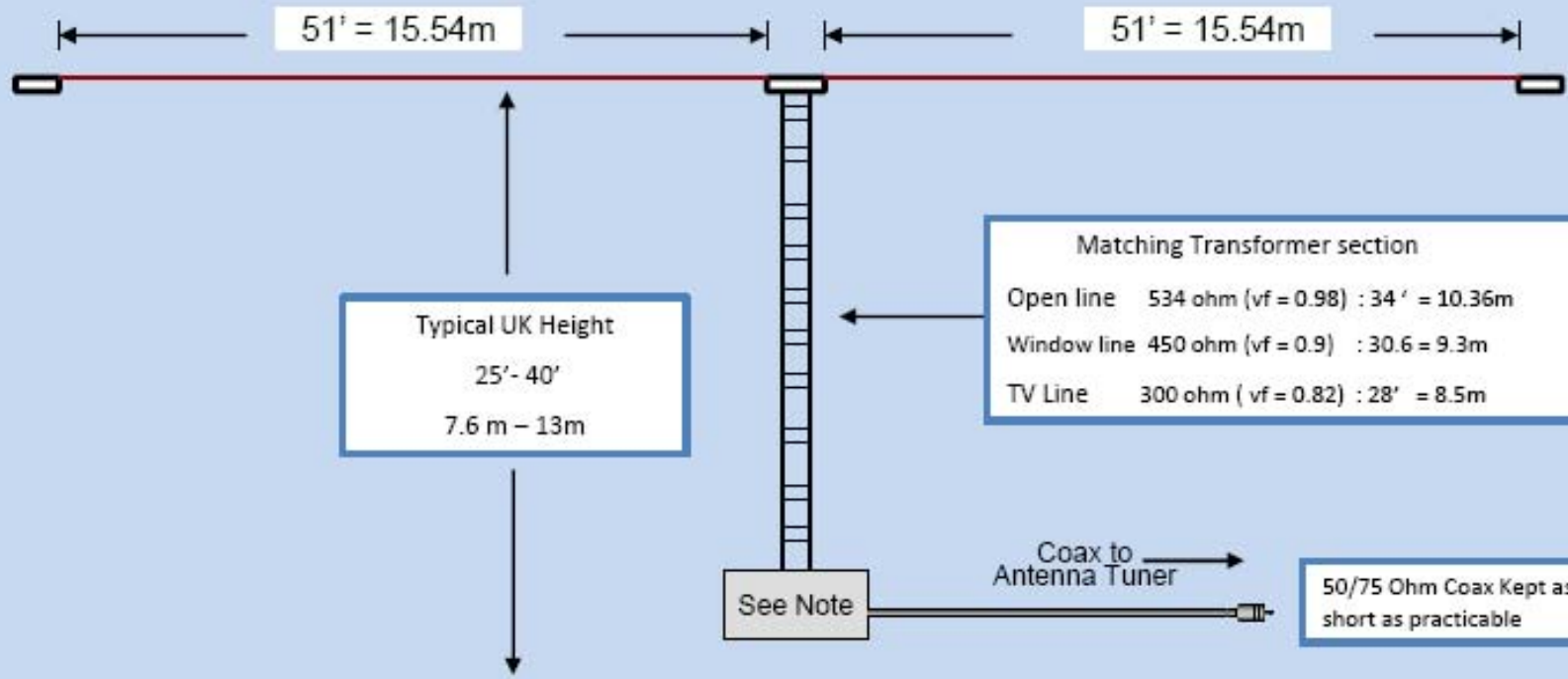

- NOTES
1. Louis Varney mentions that he used a choke BALUN . This can be made from 12-15m of coax forming a 7-9 turns coil, and tie-wrapped to form a circle 20-25 cm diameter.
 2. If the G5RV is erected lower than 12 metres, ensure that the ladder line is well clear of the ground and other objects .

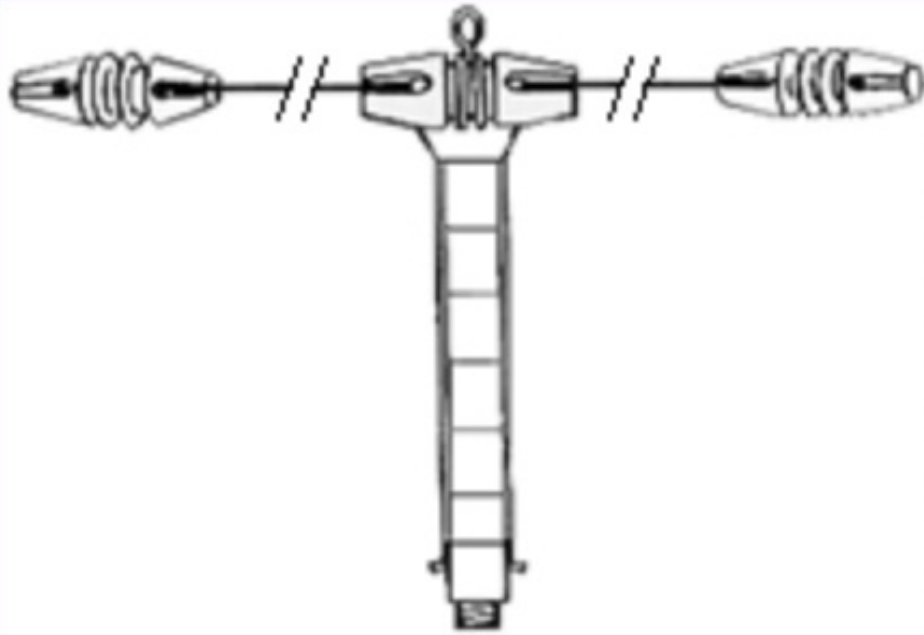

Two variations on the G5RV model. At left the commercial version G5RV-E sold by Universal Radio. At right the model sold by HFAntennas. Most cost between \$37 and...\$130 charges included. The cheapest display of course a quality much different from the "high-ends" models. However at such a price, in all your life this will be the best investment you could do in hamradio equipment ! Such an antenna makes for example a perfect second antenna dedicated to listening or to work in the field.

In practice, since the whole system will be brought to resonance by the use of an antenna tuner, the antenna is cut to 31.1m (102 ft).

This effect confers certain advantages over a trap or ferrite-bead loaded dipole because, with increasing electrical length, the major lobes of the vertical component of the polar diagram tend to be lowered as the operating frequency is increased. Thus, from 20m up, most of the energy radiated in the vertical plane is at angles suitable for dx working. Furthermore, the polar diagram changes with increasing frequency from a typical half-wave dipole pattern on 80m and a 1/2 λ wave in-phase pattern on 80m and 30m to that of a "long-wire" antenna on 20, 17, 15, 12 and 10m bands (Fig.1)

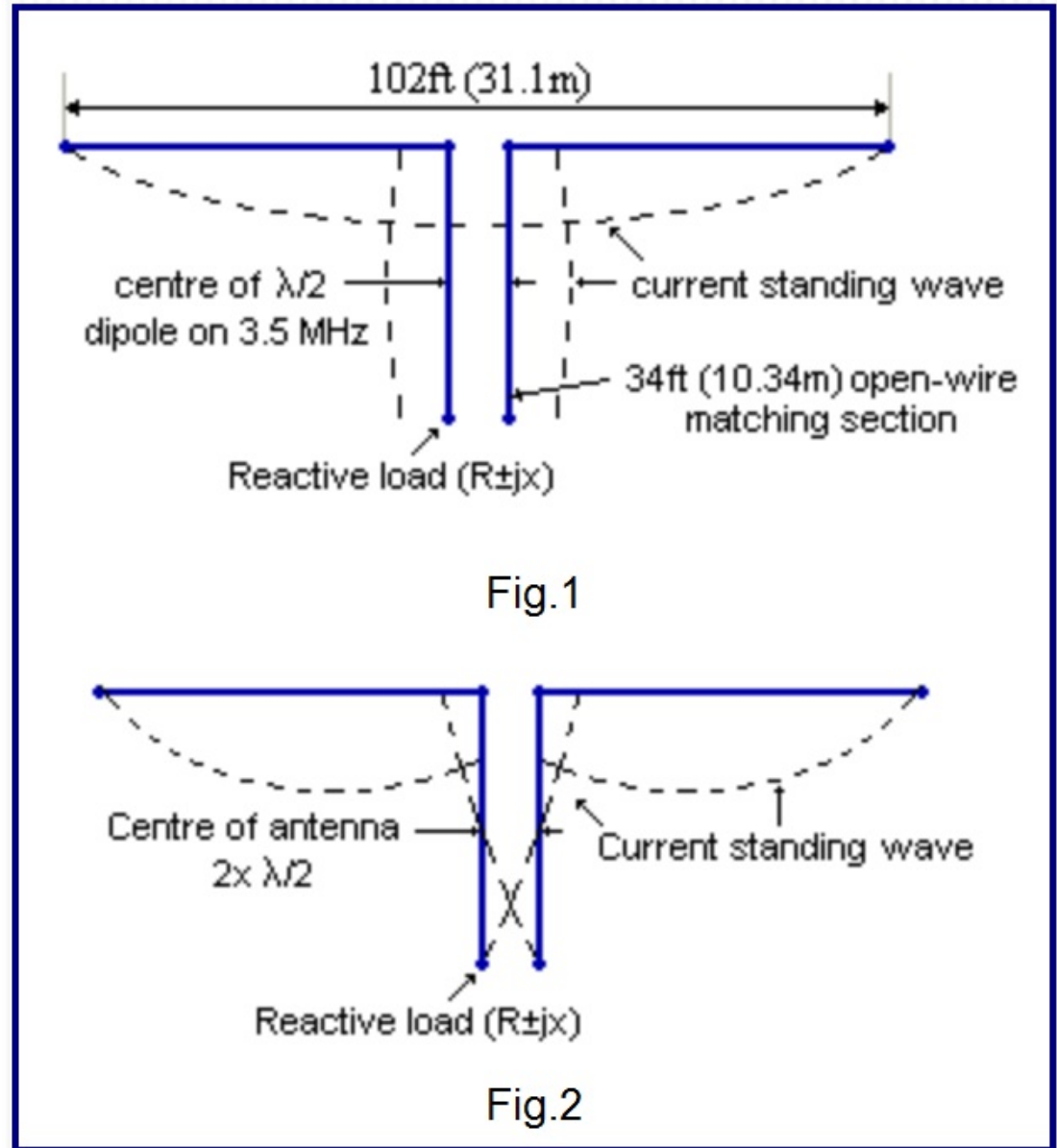

Although the impedance match for 75 ohm twinlead or 80 ohm coaxial cable at the base of the matching-section is very good on 20m band, and even the use of 50 ohm coax cable results in only about 1.8:1 VSWR on this band, the use of a suitable antenna tuner is necessary on all the other HF bands because, on those bands, the antenna plus the matching-section will present a reactive load to the feeder. thus the use of the correct type of antenna tuner (unbalanced input to balanced output if twin-wire feeder is used, or unbalanced to unbalanced if coaxial feeder is used) is essential in order to ensure the maximum transfer of power to the antenna from a typical transceiver having a 50W coaxial (unbalanced) output.

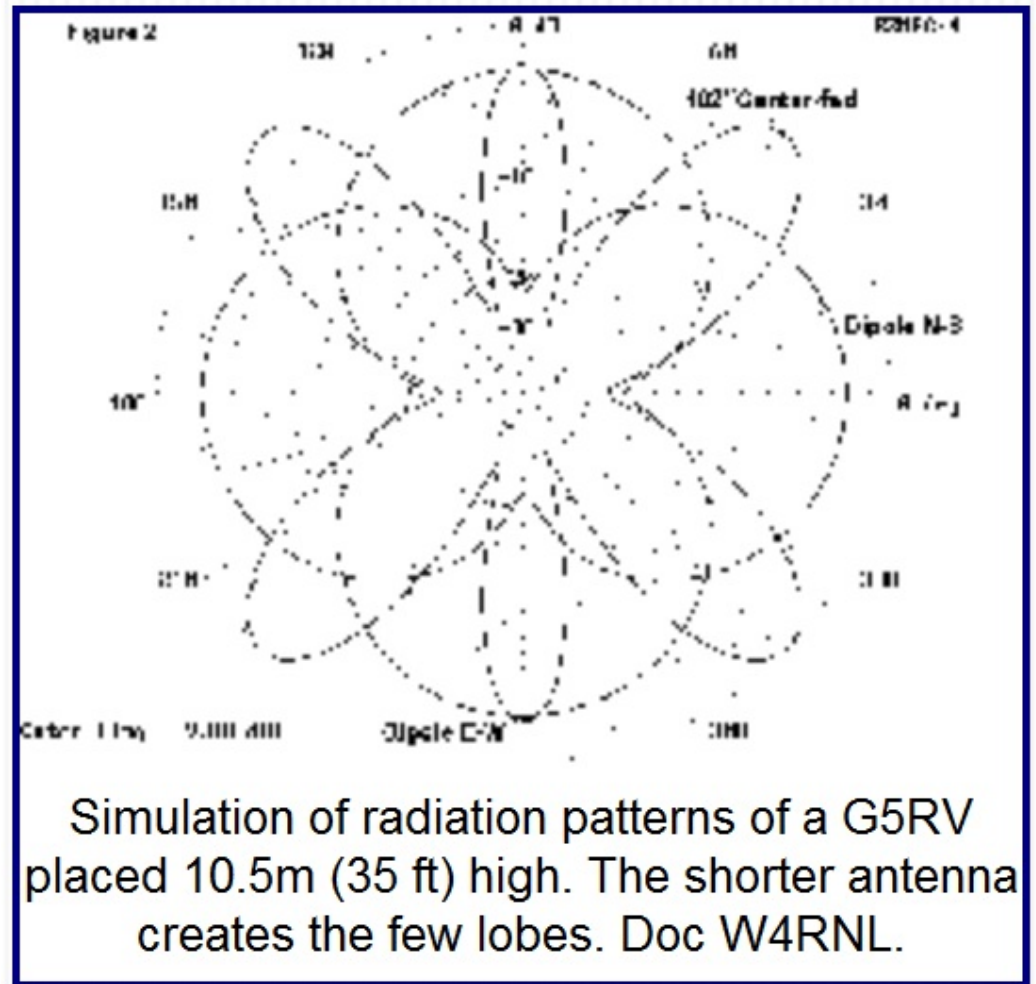

Alternately, an "unbalanced-to-unbalanced" type of antenna tuner such as a "T" or "L" matching circuit can be used. Under these conditions the "flat-top" (or inverted-V) portion of the antenna plus the matching section and feeder function as a "Marconi" or "T" antenna, with most of the effective radiation taking place from the vertical, or near vertical, portion of the system; the "flat-top" acting as a top-capacitance loading element. However, with the system fed as described above, very effective radiation on these two bands is obtainable even when the "flat-top" is as low as 7.6m (25 ft) above ground.

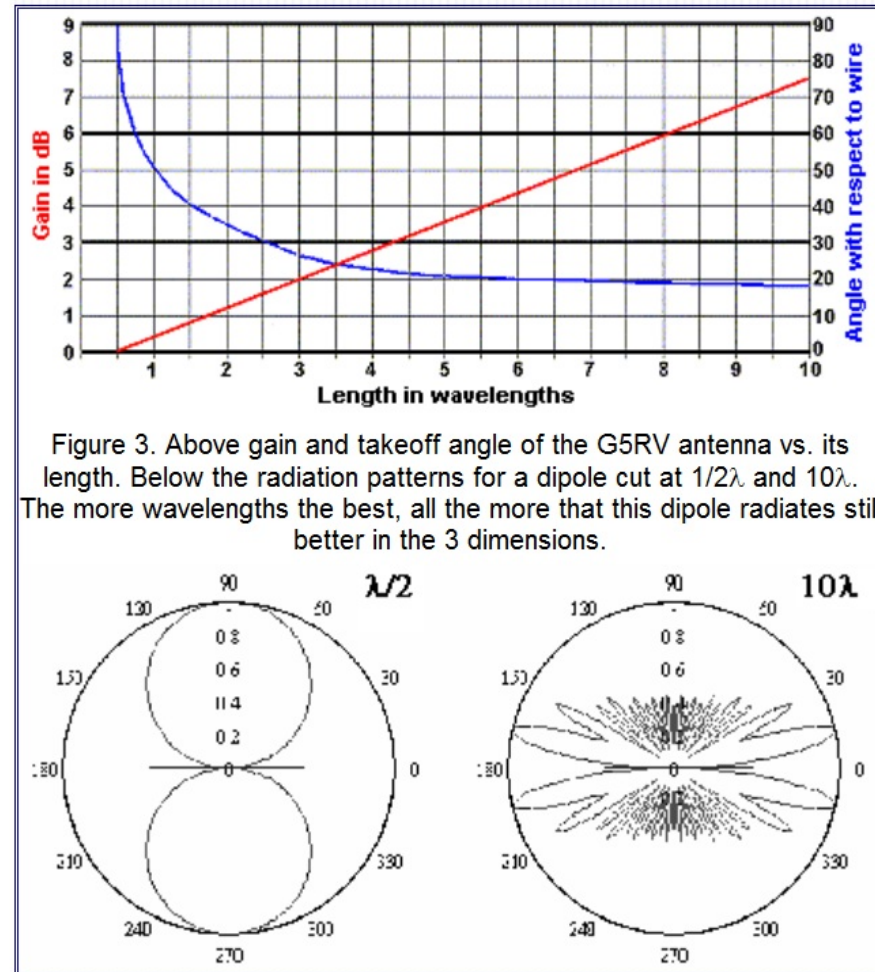
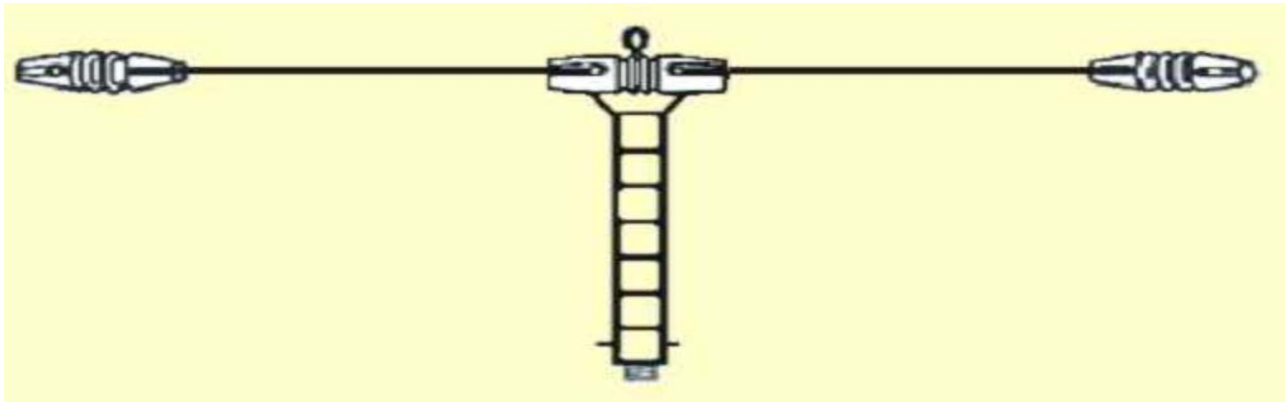
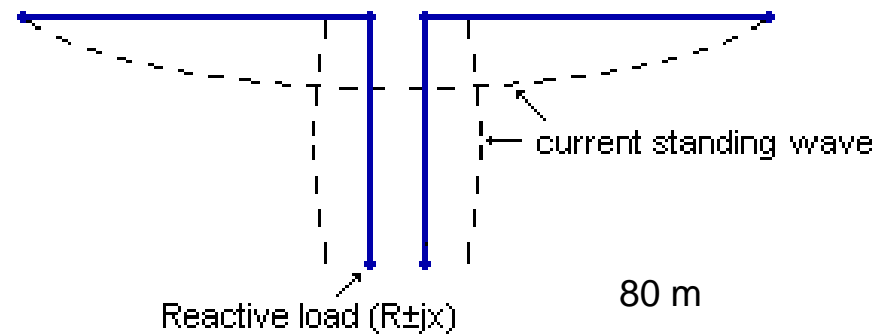
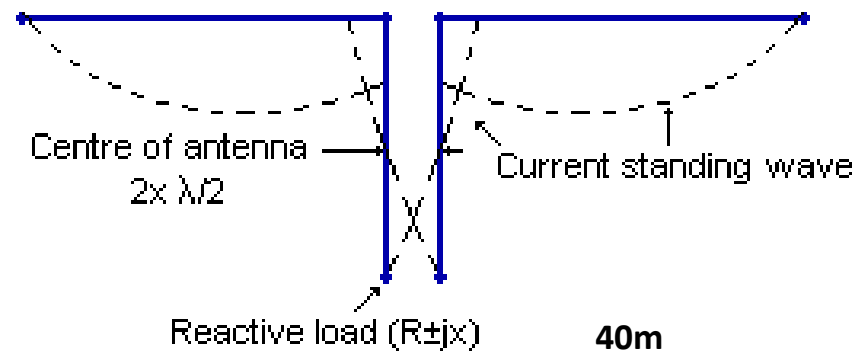
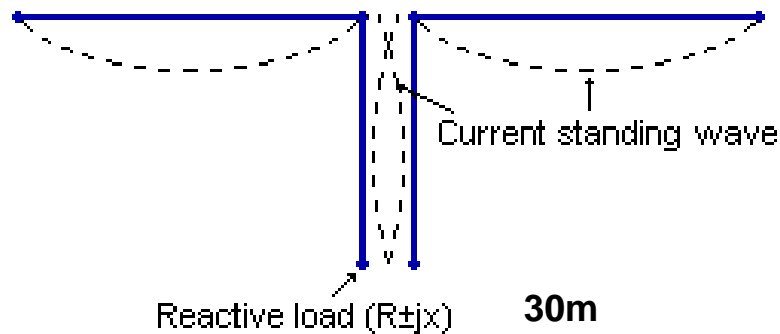

Figure 3. Above gain and takeoff angle of the G5RV antenna vs. its length. Below the radiation patterns for a dipole cut at $1/2\lambda$ and 10λ . The more wavelengths the better, all the more that this dipole radiates still better in the 3 dimensions.

Theory of Operation

The general theory of operation has been explained above; the detailed theory of operation on each band from 80 to 10m follows, aided by figures showing the current standing wave conditions on the "flat-top" and the matching (or make-up) section. The relevant theoretical horizontal plane polar diagrams for each band may be found in any specialized antenna handbooks. However, it must be born in mind that: (a) the polar diagrams generally shown in two dimensional form are, in fact, three dimensional (i.e. solid) figures around the plane of the antenna; and (b) all theoretical polar diagrams are modified by reflection and absorption effects of nearby conducting objects such as wire fences, metal house guttering, overhead electric power and telephone wires, house electric wiring system, house plumbing systems, metal masts and guy wires, and large trees. Also the local earth conductivity will materially affect the actual polar radiation pattern produced by an antenna.





Modification for 160m

To work on 160 meters with such a dipole, use a simulation software like EZNEC or the freeware DIPOLE3 and change lengths of the dipole, feedline, etc until you get a good efficiency (a low impedance and SWR with very few losses). For your information, if you place the dipole 11m high above ground and using a 10.35m long ladder line for the matching section you could get an efficiency of 40% but only... in extending the dipole to 84m and using 15m of coax. Your VSWR on the feedline will be ~13:1, with 3.8 dB of overall loss or 0.5 S-points. Less than half of your power will be emitted in such conditions... The best efficiency, 81%, is got using 45m of Belden 9913 coax and placing the dipole 40 meters high !

20m. At this frequency the conditions are ideal. The "flat-top" forms a three-half-wave long centre-fed antenna which produces a multi-lobe polar diagram with most of its radiated energy in the vertical plane at an angle of about 14° , which is very effective for DXing. Since the radiation resistance at the centre of a three-half-wave long-wire antenna supported at a height of $1/2\lambda$ above ground of average conductivity is about 90 ohm, and the 10.36m (34 ft) matching section now functions as a 1:1 impedance transformer, a feeder of anything between 75 and 80 ohm characteristic impedance will "see" a non-reactive (i.e. resistive) load of about this value at the base of the matching section, so that the VSWR on the feeder will be very nearly 1:1. Even the use of 50 ohm coaxial feeder will result in a VSWR of only about 1.8:1. It is here assumed that 10.36m (34 ft) is a reasonable average antenna height in amateur installations (Fig.7 below).

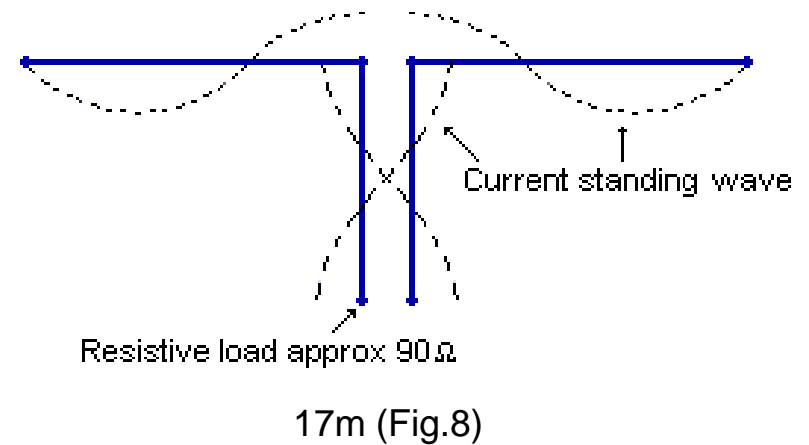
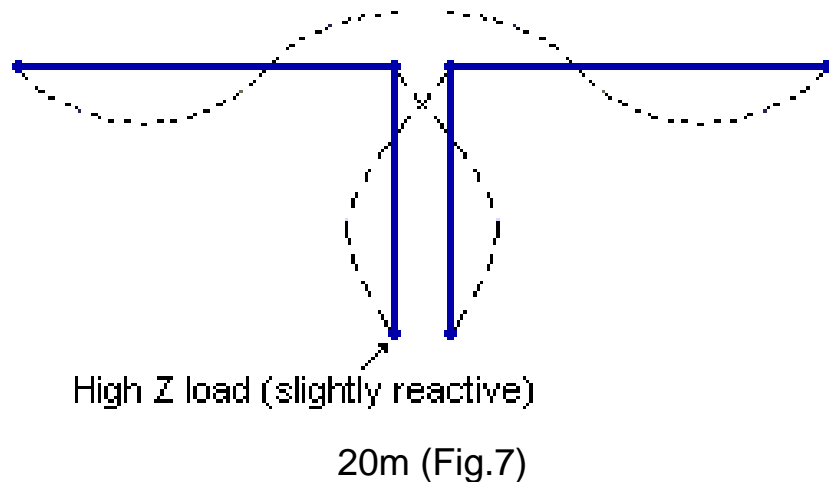

17m. The antenna functions as two full-wave antennas fed in phase; combining the broadside gain of a two-element colinear array with somewhat lower zenith angle radiation than a half-wave dipole due to its long-wire characteristic (Fig.8 above).

15m. On this band the antenna works as a "long-wire" of five half-waves, producing a multilobe polar diagram with very effective low zenith angle radiation. Although a high resistive load is presented to the feeder at the base of the make-up section, the system loads very well when used in conjunction with a suitable antenna tuner and radiates very effectively for DX contacts (Fig.9).

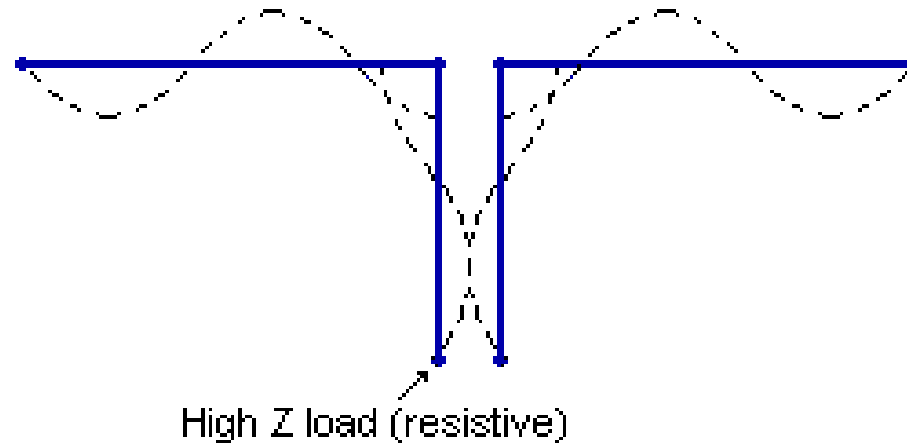

Fig 9.

- **12m.** The antenna again functions effectively as a five-half-wave "long-wire" but, because of the shift in the positions of the current anti-nodes on the flat-top and the matching section, as may be seen from Figure 10 below the matching or "make-up" section now presents a much lower resistive load condition to the feeder connected to its lower end than it does on the 15m band. Again, the polar diagram is multilobed with low zenith angle radiation.

The Antenna

The dimensions of the antenna and its matching section are shown in the drawing displayed below. The "flat-top" should, if possible, be horizontal and run in a straight line, and should be erected as high as possible above ground. In describing the theory of operation, it has been assumed that it is generally possible to erect the antenna at an average height of about 10.35m (34 ft), which happens to be the optimum radiation efficiency on 160, 80 and 40m bands for any horizontal type antenna, in practice few amateurs can install masts of the optimum height of half a wavelength on 80 or 40m, and certainly not on 160m.

If, due to limited space available, or to the shape of the garden, it is not possible to accommodate the 31.1m (102 ft) top in a straight line, up to about 3m (10 ft) of the antenna wire at each end may be allowed to hang vertically or at some convenient angle, or be bent in a horizontal plane, with little practical effect upon performance. This is because, for any resonant dipole antenna, most of the effective radiation takes place from the centre two-thirds of its length where the current antinodes are situated. Near to each end of such an antenna, the amplitude of the current standing wave falls rapidly to zero at the outer extremities; consequently, the effective radiation from these parts of the antenna is minimal.

$$\text{Length (ft)} = 492 (n - 0.015) / \text{MHz} = 492 \times 2.95 / 14.15 = \sim 102 \text{ ft (31m)}$$

where n equals the number of half-wavelengths of the wire (flat-top).

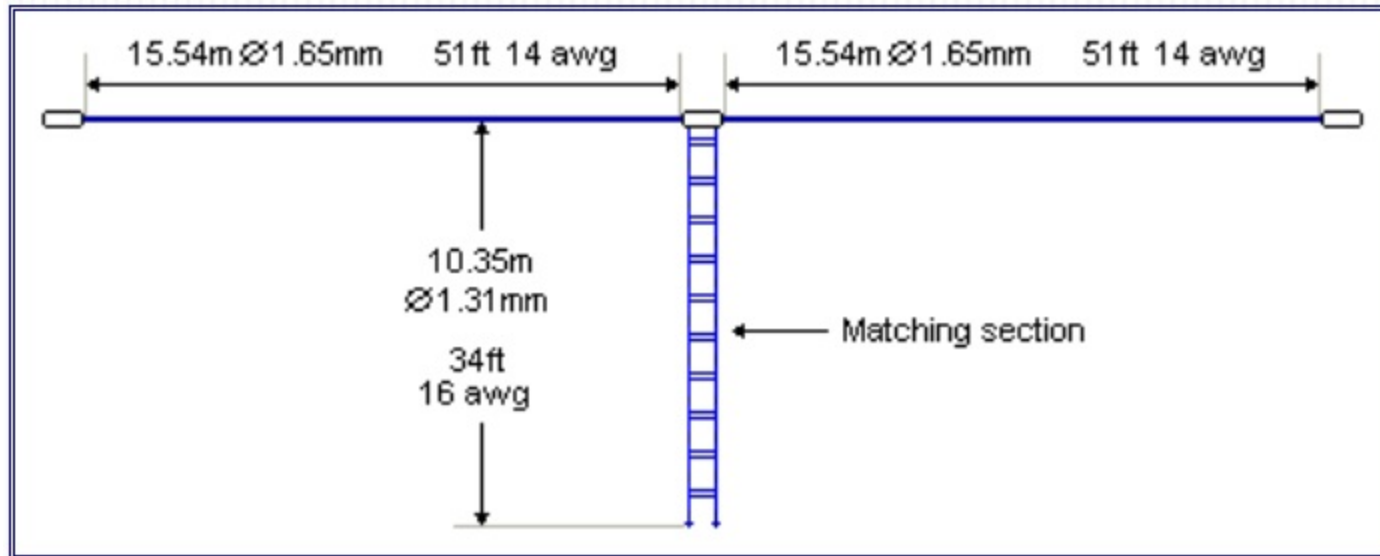

The antenna may also be used in the form of an inverted-V. However, it should be borne in mind that, for such a configuration to radiate at maximum efficiency, the included angle at the apex of the V should not be less than about 120° (although many authors consider an opening between 90-120° only); The use of #14 AWG (inner Ø1.63mm) enameled copper wire (stranded) is recommended for the flat-top or V, although thinner gauges such as #16 (inner Ø1.31mm) or even #18 AWG (inner Ø1.04mm) solid wire can be used. If the wire has to sustain a strong traction, a stranded steel wire of #14 AWG protected with PVC is also suitable.

The Matching Section

This should be, preferably, of open-wire feeder construction for minimum loss. Since this section always carries a standing-wave of current (and voltage) its actual impedance is unimportant. A typical, and very satisfactory, form of construction is shown below. The feeder spreaders may be made of any high-grade plastic strips or tubing; the clear plastic tubing sold for beer or wine siphoning is ideal.

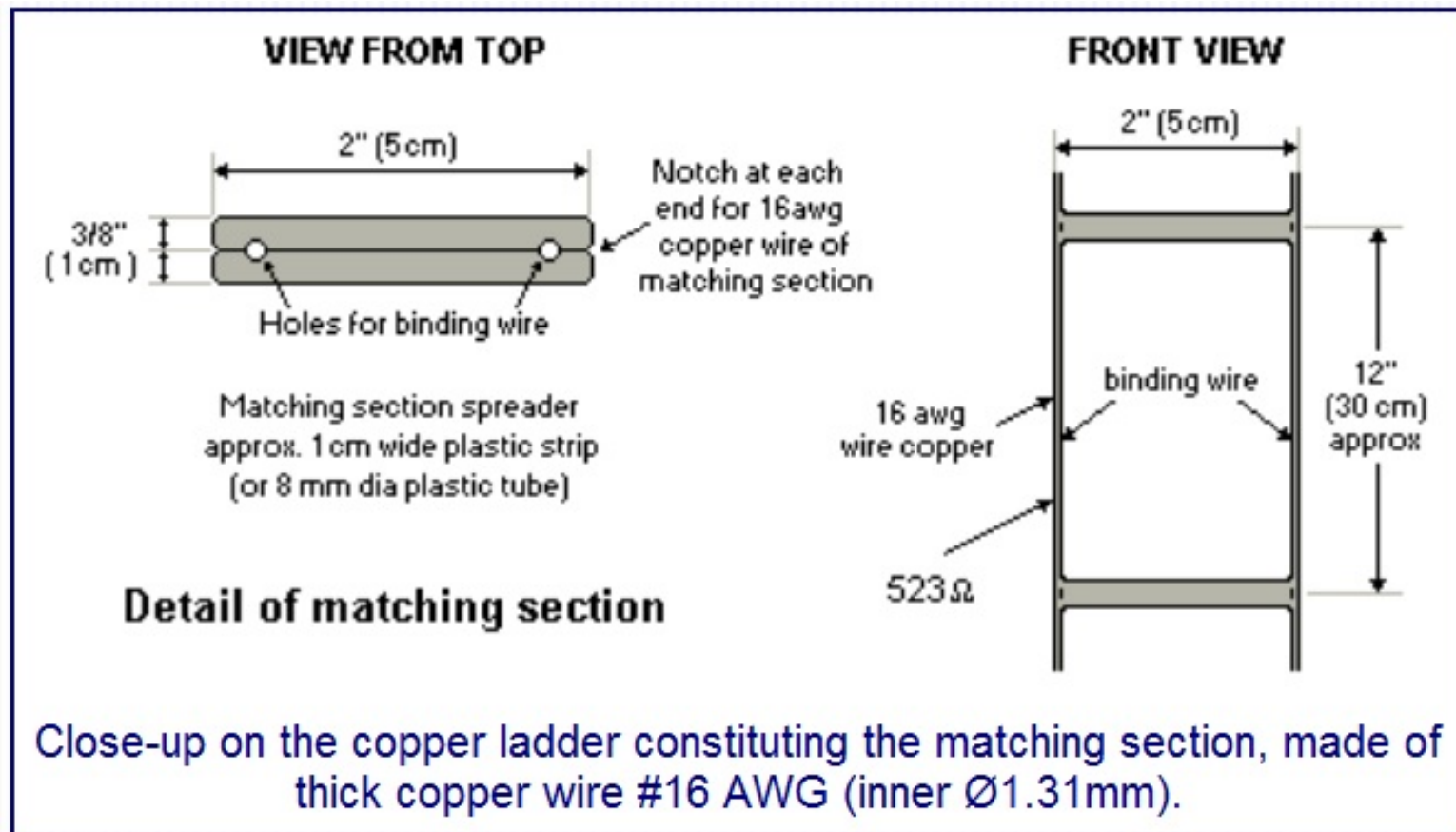

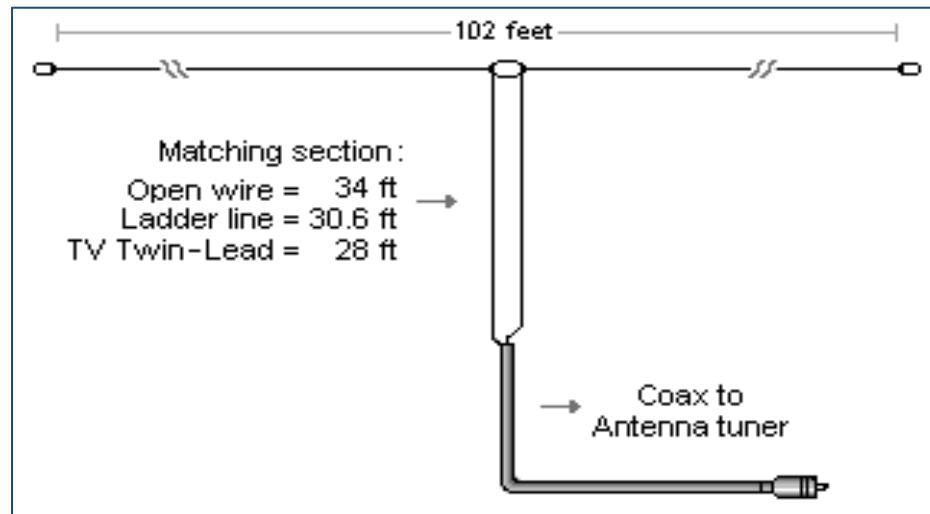

- If it is desired to use 300 ohm ribbon type feeder for this section, it is strongly recommended that the type with "windows" (ladder line) be used because of its much lower loss than that with solid insulation throughout its length, and its relative freedom from the "detuning" effect caused by rain or snow. If this type of feeder is used for the matching section, allowance must be made for its velocity factor in calculating the mechanical length required to resonate as a half-wave section electrically at 14.150 MHz. Since the velocity factor of standard 300 ohm ribbon feeder is 0.82, the mechanical length should be 8.5m (28 ft). However, if 300 ohm ribbon with "windows" is used, its velocity factor will be almost that of open-wire feeder, say 0.90, so its mechanical length should be 9.3m (30.6 ft). This section should hang vertically from the centre of the antenna for at least 6.1m (20 ft) or more if possible. It can then be bent and tied off to a suitable post with a length of nylon or terylene cord so as to be supported at above head-height to the point where, supported by a second post, its lower end is connected to the feeder.

The Feeder

The antenna can be fed by any convenient type of feeder provided always that a suitable type of antenna tuner is used. In the original article describing the G5RV antenna, then in RSGB bulletin November 1966, it was suggested that if coaxial cable feeder was used, a balun might be employed to provide the necessary unbalanced-to-balanced transformation at the base of the matching section. This was because the antenna and its matching section constitute a balanced system, whereas a coaxial cable is an unbalanced type of feeder. However, later experiments and a better understanding of the theory of operation of the balun indicated that such a device was unsuitable because of the highly reactive load it would "see" at the base of the matching or "make-up" section on most HF bands.

It is now known that if a balun is connected to a reactive load presenting a VSWR of more than about 2:1, its internal losses increase, resulting in heating of the windings and saturation of its core (if used). In extreme cases, with relatively high power operation, the heat generated due to the power dissipated in the device can cause it to burn out as well as the PL jacks. However, the main reason for not employing a balun in the case of the G5RV antenna is that, unlike an antenna tuner which employs a tuned circuit, the balun cannot compensate for the reactive load condition presented to it by the antenna on most of the HF bands, whereas a suitable type of antenna tuner can do this most effectively and efficiently.

Recent experiments by Louis Varney to determine the importance or otherwise of "unbalance" effects caused by the direct connection of a coaxial feeder to the base of the matching section had a rather surprising result. They proved that, in fact, the HF currents measured at the junction of the inner conductor or the coaxial cable with one side of the (balanced) matching section and at the junction of the outer coaxial conductor (the shield) with the other side of this section are virtually identical on all bands up to 10m, where a slight but inconsequential difference in these currents has been observed. There is, therefore, no need to provide an unbalanced-to-balanced device at this junction when using coaxial feeder.

However, the use of an unbalanced-to-unbalanced type of antenna tuner between the coaxial output of a modern transmitter (or transceiver) and the coaxial feeder is essential because of the reactive condition presented at the station end of this feeder which, on all but the 20m band, will have a fairly high to high VSWR on it. This VSWR, however, will result in insignificant losses on a good-quality coaxial feeder of reasonable length; say, up to about 21.3m (70 ft). Because it will, inevitably, have standing waves on it, the actual characteristic impedance of the coaxial cable is unimportant, so that either 50 Ω or 80 Ω type can be used.

Impedance of a ladder line

Assuming that you use round wires, and air dielectric, the impedance is approximatively :

$$W = 120 \ln (2 \cdot D/d)$$

with W, the impedance in ohm

ln, the natural logarithm

D, the wire spacing, center to center (from 30 to over 150 mm)

d, the wire diameter (from #14 to #18 AWG)

So, to get W ohms for a given wire diameter d, apply the next formula :

$$D = d \cdot e^{(W/120)}/2$$

Here are some usual values :

Impedance (Ω)	D/d
150	1.9
200	2.8
300	6.2
450	22
600	75

Another very convenient type of feeder that may be used is 75 ohm Twin-Lead. However, because of the relatively high loss in this type of feeder at frequencies above about 40m, especially when it has a high VSWR on it, it is recommended that not more than about 15 to 18m (50 to 60 ft) of this type feeder be used between the base of the matching section and the antenna tuner. Unfortunately the 75 ohm Twin-Lead in the UK is the receiver type; the much less lossy transmitter type is available in the U.S.A.

By far the most efficient feeder is the "open-wire" type. A suitable length of such feeder can be constructed in exactly the same way as that described for the open-wire matching section. If this form of feeder is employed, almost any convenient length may be used from the centre of the antenna right to the antenna tuner (balanced) output terminals. In this case, of course, the matching section becomes an integral part of the feeder. A particularly convenient length of open-wire feeder is 25.6m (84 ft), because such a length permits parallel tuning of the antenna tuner circuit on all bands from 80 to 10m with conveniently located coil taps in the antenna tuner coils for each band, or, where the alternative form of antenna tuner employing a three-gang 500 pF/section variable coupling capacitor is used the optimum loading condition can be achieved for each band. However, this is not a rigid feeder length requirement and almost any length that is mechanically convenient may be used. Since this type of feeder will always carry a standing wave, its characteristic impedance is unimportant, and sharp bends, if necessary, may be used without detriment to its efficiency. It is only when this type of feeder is correctly terminated by a resistive load equal to its characteristic impedance that such bends must be avoided.

Coaxial cable HF choke

Under certain conditions, either due to the inherent "unbalanced-to-balanced" effect caused by the direct connection of a coaxial feeder to the base of the (balanced) matching section, or to pick-up of energy radiated by the antenna, a current may flow on the outside of the coaxial outer conductor. This effect may be considerably reduced, or eliminated, by winding the coaxial cable feeder into a coil of 8 to 10 turns about 15 cm (6") in diameter immediately below the point of connection of the coaxial cable to the base of the matching section. The turns may be taped together or secured by nylon cord. However this construction can become the source of problems during thundery weathers.

How to tune a 40-meter dipole antenna on 15 meters ?

Louis Varney didn't deal with this solution that can be very useful if you want to work with a half-size dipole cut for 7 MHz (about 20m long) on harmonics like the 15m band. But we all know that this wavelength is out of band for phone work (USB) in most ITU Regions (because $7.2 \times 3 = 21.6$ MHz). By what miracle can we use this dipole on 21 MHz ? The solution is really simple and consists in charging the antenna with a capacitance hat, one on each segment. How to proceed ?

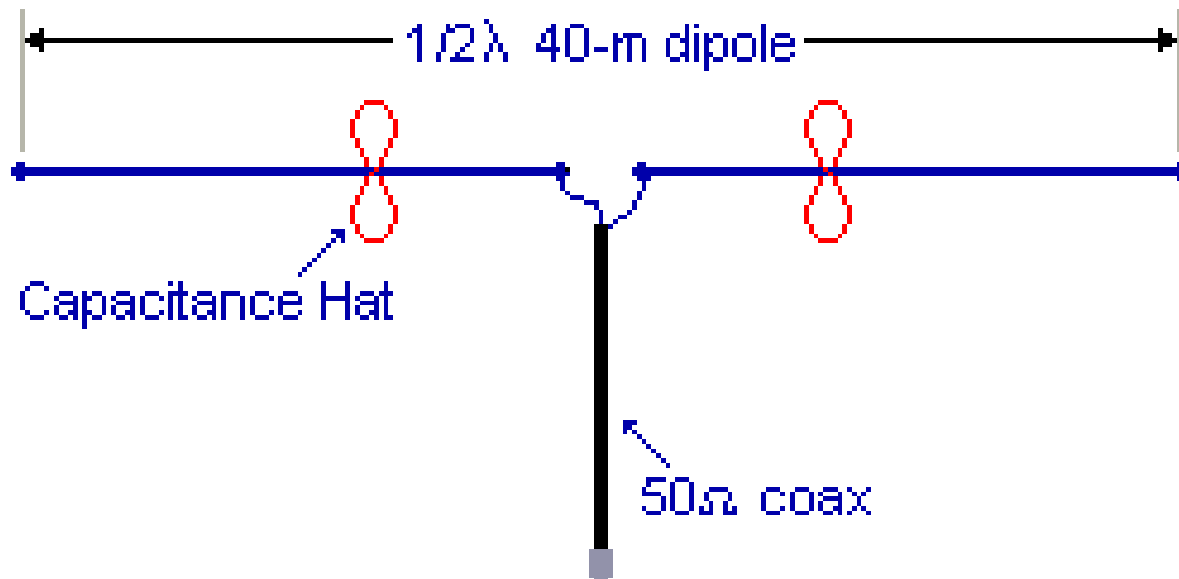

Cut two-60 cm long (2 ft) pieces of thick wire (#12 or #14 house wiring) and solder the ends of each piece together to form 2 loops. Twist the loops in the middle to create a two figure 8s. Solder the twisted centers of your figure 8s to each leg of your dipole at a point about a third of the way from the feed point (position is not critical). Adjust the loop shape and take measurement on 15m band until you reach an acceptable SWR on your working frequency. Your SWR on 40m should only see a minor variation.

Modified G5RV HF Antenna

Water-proof you said ?

It is important, of course, that the junction of the coaxial cable to the matching section be made thoroughly water-proof and stays dry by any of the accepted methods; binding with several layers of plastic insulating tape or self-amalgamating tape and then applying two or three coats of polyurethane varnish, or totally enclosing the end of the coaxial cable and the connections to the base of the matching section in a sealant such as epoxy resin. At WiMo for example the 4:1 balun coming with their G5RV is designed such a way that it protects the SO-239 connector from the rain when it is hanged in vertical position, the coaxial being screwed over 2 cm inside the balun. However if you work with high power I warmly suggest you to place the balun and its connector inside a small home-maded weatherproof box or, better, to use a small electrical box for outdoor installations so that all connexions stay dry.

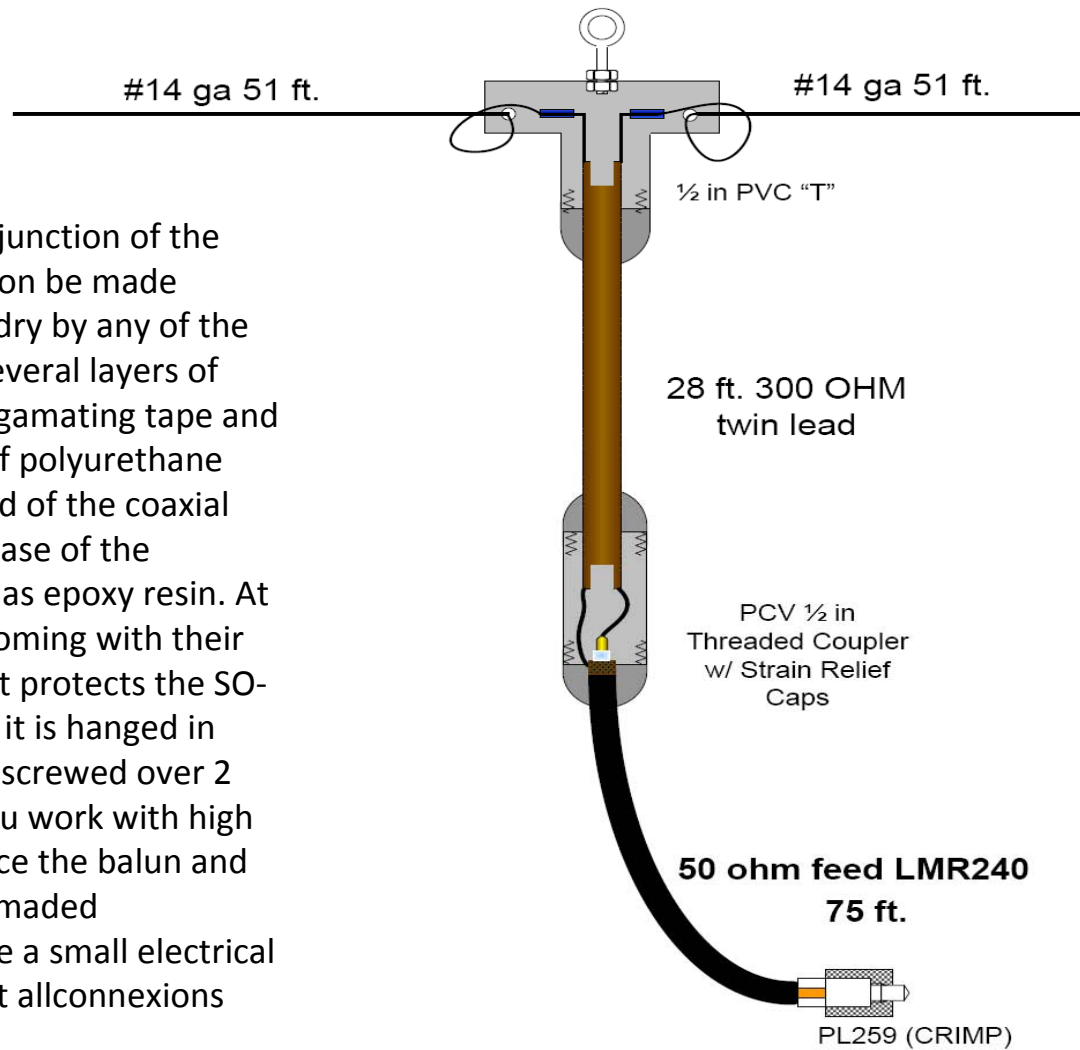

DRAWN BY: Randy Emerzian – K6VAU

THANK YOU!

Have fun with the G5RV !

For more information

<http://www.universal-radio.com/>

<http://www.hfantennas.com/>

<http://usa2way.homestead.com/>

<http://www.mapleleafcom.com/>

<http://www.wsplc.com/>

<http://www.mfjenterprises.com/>

<http://www.sarradio.com/>

Jim Thompson's FAQ Book :

<http://www.radioworks.com/Book/82/82.html>

This article was first printed in RADIO COMMUNICATIONS, July 1984.

Extracted from ON4SKY, Thierry's website at <http://www.astrosurf.org/luxorion/qsl-g5rv-print.htm>

This presentation was prepared by Randy Emerzian – K6VAU, Jan 6, 2011
for use by the Amateur Radio Association of Central California.